

ITEM NO.	PART NO.	DESCRIPTION	QTY.
1	H135V	Cuff-Lynx, 2" male cuff x 2" mpt, vinyl	1
2	P583	vac tank, MyteeLite	1
3	H312	plate, connecting, MyteeLite	4
4	H230	screw, 10-32 x 1/2" phil pan head, s/s	23
5	G036	cap, 2.5" threaded, tethered	1
6	H423	plug, 7/8", black, heyco	2
7	H222	screw, 10-32 x 1-1/4" phil pan head, s/s	7
8	H688-A	handle w/ basket, MyteeLite	1
9	G055	tether, cap, 6 1/2"	1
10	P560	cap, 6", threaded	1
11	G031	gasket, 3.25" i.d. x 5.80" o.d.	1
12	G022	filter, foam, 2.50" x .50"	1
13	G021	screen, mesh filter, 2.48" dia	1
14	H203	bolt, 1/4-20 x 1-1/4" hex head, s/s	2
15	H210	washer, 1/4" flat, s/s	13
16	H216	nut, lock, 1/4-20, nylon insert, s/s	2
17	H213	washer, 1/4" lock, s/s	2
18	H201	bolt, 1/4-20 x 1/2" hex head, s/s	2
19	H846B	cap, gallon jug, 1-5/8"	1
20	H379	bracket, front, small	1
21	P584	sol tank, MyteeLite	1
22	G004	gasket, vacuum motor	2
23	C304P	vac motor, 3 stage, 100", 87 cfm, 230v	1
24	H178	faucet fill	1
25	B241	adapter, brass, 3/8" barb x 1/4"mpt	1
26	PH612-60	clear tubing, 1/2" OD x 3/8" ID, faucet fill	1
27	H273	nut, kep, #10-32 zinc	20
28	H681	caster, 2", black hub, gray tread	2
29	P585	base, MyteeLite	1
30	H241	axle, 13.63" x .50" dia	1
31	H279	wheel, 6"	2
32	H042	c-clip, 12mm, external	2
33	H254	washer, axle, cut 1/2" id	4
34	H029	screw, plastite, 10 x 1/2", s/s	4
35	H289	washer, 10 flat, s/s	1
36	H389	screw, 10-32 x 1/2" SHCS, alloy	1
37	E515	switch, rocker, 2 position	3
38	E531	power cord, end, 25', 12/3 black	1
39	H220	fitting, strain relief, cord	1
40	H310	plate, switch, MyteeLite, 3 hole	1
41	H221	nut, lock, 1/2" steel, electrical	1
42	H486	latch, front, set, large	1
43	G068	bumper, 7/8" x 1/4" head	2
44	B652	elbow, 90 deg, 3/8"mpt x 1/4"mpt	1
45	B142	coupling, 1/4" fpt x 1/4" fpt	1
46	AH184	sol hose, pulse, 1/4" x 14.5", 1/4 msw x 1/4 fpt	1
47	C306	pump, 120 psi, 230V	1
48	B170	ferrule, 1/4" brass	2
49	B105	bushing, brass, 3/8"mpt x 1/4"	1
50	B152	elbow, brass, 90 deg, 1/4" barb x 1/4" mpt	1
51	PH634-15	sol hose, 1/4" silicone braided, clear	1
52	B110	adapter, brass, 1/4" sw barb x 1/4" fpt, w/gasket	1
53	B119	filter, strainer, 1/4"	1
54	H212	flat washer, 9/16"ID x 1 1/16"OD, AN960-C916	2
55	B107	nipple, hex, 1/4"mpt x 1/4"mpt	2
56	B103	elbow, 90 deg street, 1/4"mpt x 1/4" fpt	1
57	A901A	heater, 1000wt, 230v	1

ITEM NO.	PART NO.	DESCRIPTION	QTY.
58	B108	valve, brass, 1/4" check	1
59	B207	elbow, brass, 90 deg, 1/4" fpt x 1/4" fpt	2
60	AH106	sol hose, 1/4" x 10", 1/4 msw x 1/4 fpt	1
61	H484	plate, mounting, QD	1
62	H256	screw, 10-32 x 3/4" phil pan head	4
63	B102	quick disconnect, 1/4" fqd x 1/4" fpt	1

ITEMS NOT SHOWN

PART NO.	DESCRIPTION	QTY.
ADM-8070	manual, Mytee-Lite	1
A110	drain hose w/plug, barb cap, 8070	1
E997	harness, electrical	1
G036	cap, 2.5" threaded, tethered	1
G079	hose wrap, heat guard	1
H122V	Cuff-Lynx, 2" fem cuff x 1.25" fem vac hose, vinyl	1
H133	Cuff-Lynx, 1-1/4" hose x male & female	2
P590	cuties, 1/4" qd, strandard pack of 2	1
8501	hose assem, vac/sol, 15' x 1-1/4", cuff, hose in cuff	1
8400P	upholstery tool, Air Lite	1

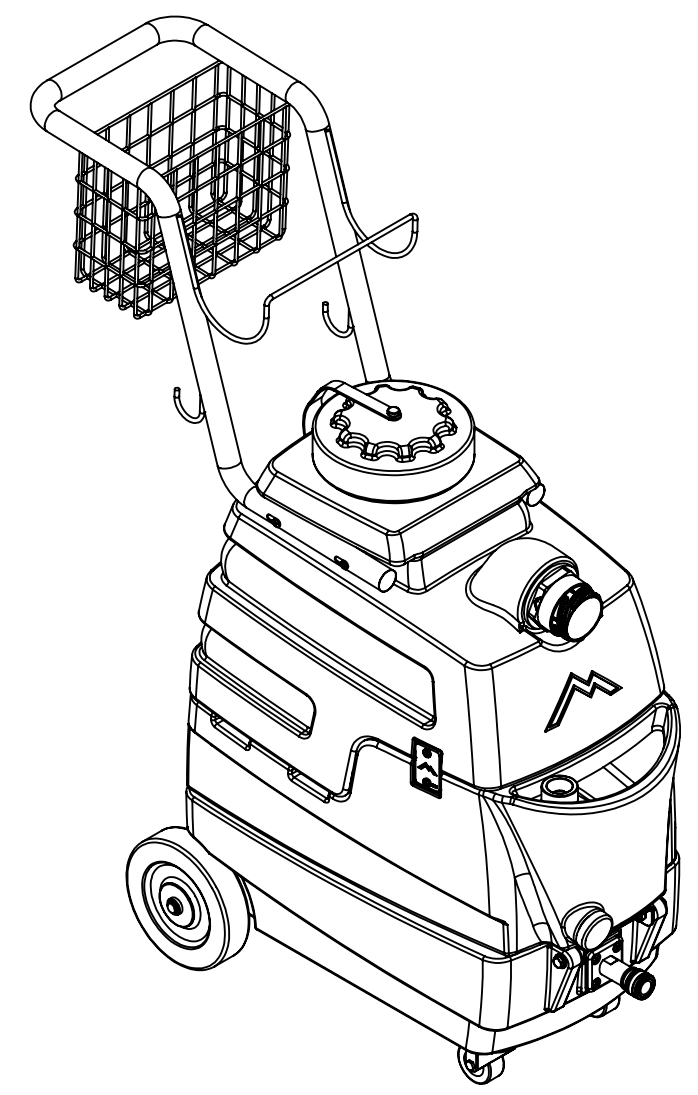

NAME		DATE		MYTEE <small>858-679-1191</small>	
DRAWN	M.LaBarbera	1/2014			
CHECKED				TITLE:	
COMMENTS:				Mytee Lite	
<small>PROPRIETARY AND CONFIDENTIAL</small> <small>THE INFORMATION CONTAINED IN THIS DRAWING IS THE SOLE PROPERTY OF MYTEE LLC. ANY REPRODUCTION IN PART OR AS A WHOLE WITHOUT THE WRITTEN PERMISSION OF MYTEE LLC IS PROHIBITED.</small>					
SIZE	DWG. NO.	REV			
C	8070-230	F			
SCALE: 1:24	DO NOT SCALE DRAWING	SHEET 1 OF 5			

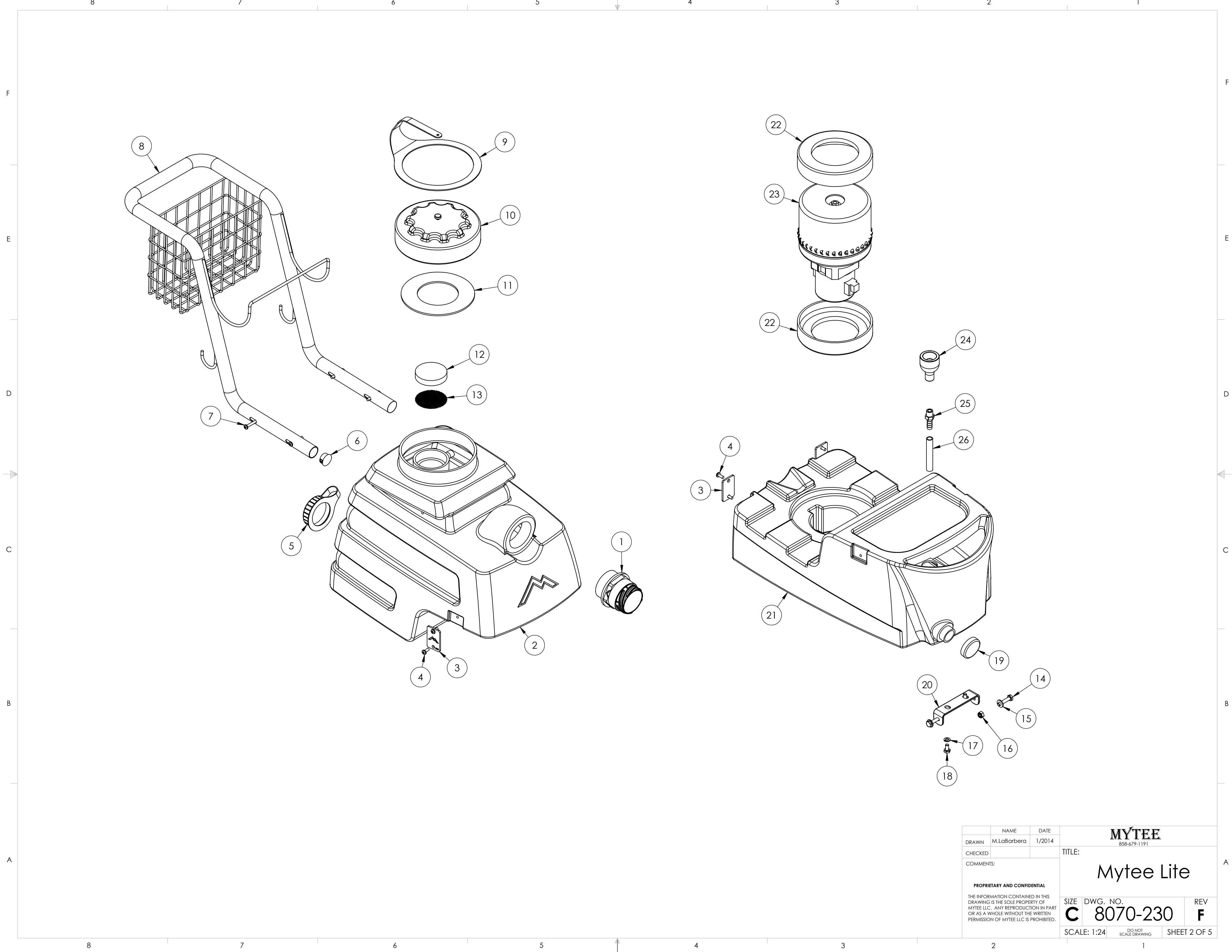

	NAME	DATE	MYTEE 858-679-1191		
DRAWN	M.LaBarbera	1/2014			
CHECKED			TITLE:		
COMMENTS:			Mytee Lite		
<small>PROPRIETARY AND CONFIDENTIAL</small> <small>THE INFORMATION CONTAINED IN THIS DRAWING IS THE SOLE PROPERTY OF MYTEE LLC. ANY REPRODUCTION IN PART OR AS A WHOLE WITHOUT THE WRITTEN PERMISSION OF MYTEE LLC IS PROHIBITED.</small>			SIZE	DWG. NO.	REV
			C	8070-230	F
SCALE: 1:24			DO NOT SCALE DRAWING	SHEET 2 OF 5	

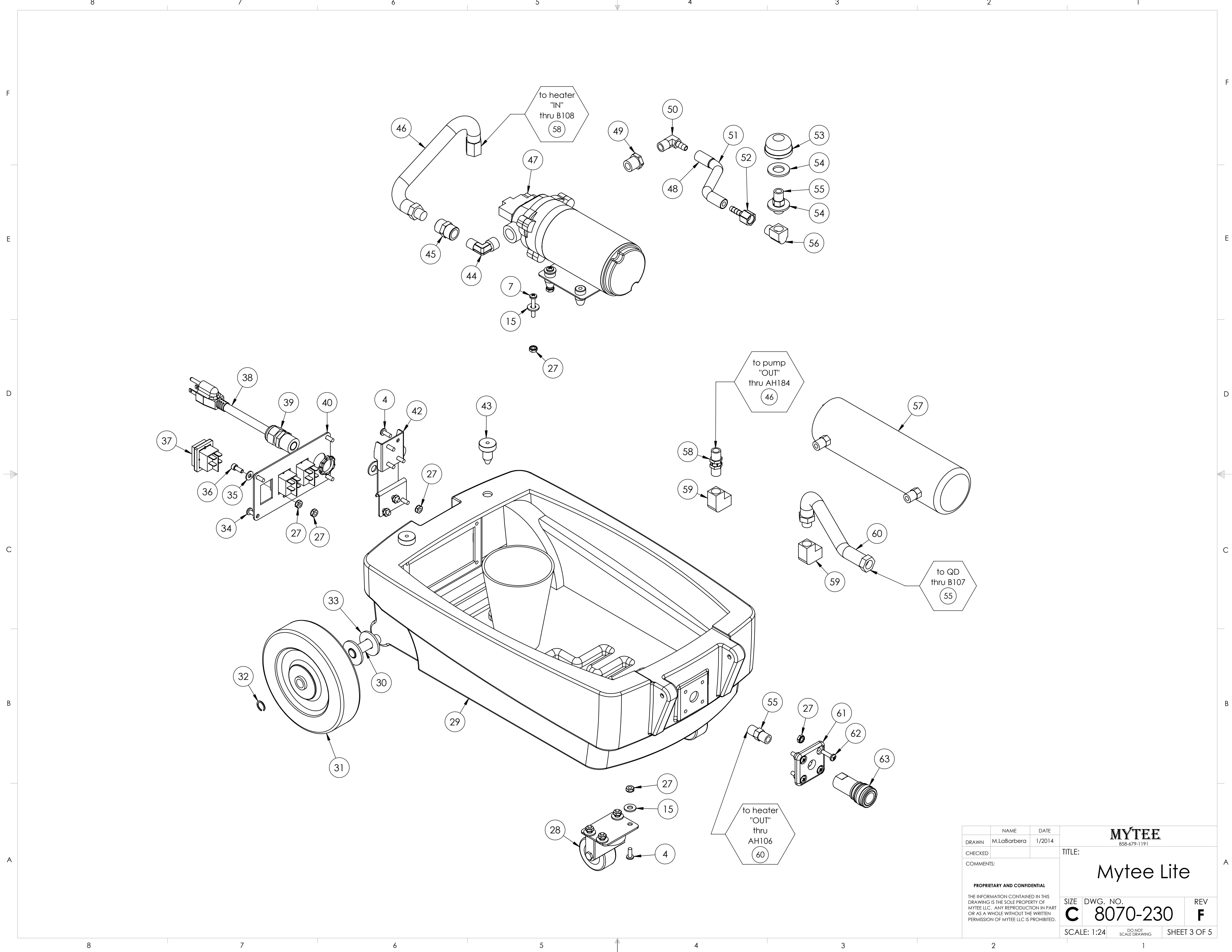

	NAME	DATE	MYTEE 858-679-1191	
DRAWN	M.LaBarbera	1/2014		
CHECKED			TITLE: Mytee Lite	
COMMENTS:				
<small>PROPRIETARY AND CONFIDENTIAL</small> <small>THE INFORMATION CONTAINED IN THIS DRAWING IS THE SOLE PROPERTY OF MYTEE LLC. ANY REPRODUCTION IN PART OR AS A WHOLE WITHOUT THE WRITTEN PERMISSION OF MYTEE LLC IS PROHIBITED.</small>			SIZE DWG. NO. C 8070-230	REV F
SCALE: 1:24			DO NOT SCALE DRAWING	SHEET 3 OF 5

ITEM NO.	E519	DESCRIPTION	QTY.
1	H903A	heater, aluminum cast, single	1
2	E520	heating rod, 1000W, 230V	1
3	E573	Thermostat, 200°, Auto, 1/4"	1
4	E574	Thermostat, 310°F ± 10°F, Manual, 1/4"	1
5	H274	screw, 6 x 3/16, phil pan head, self-tapping	5

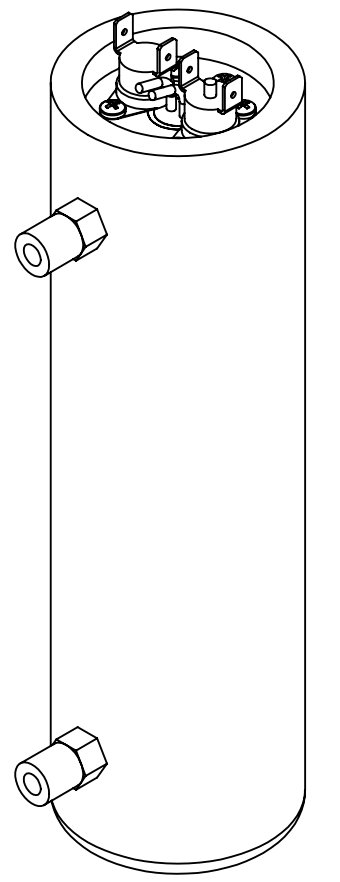
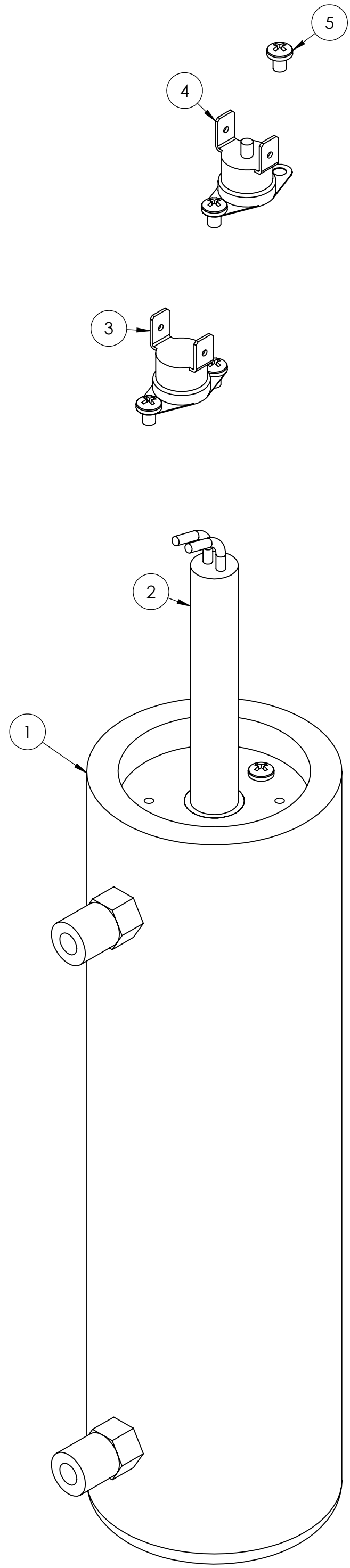

	NAME	DATE	MYTEE 858-679-1191		
DRAWN	M.LaBarbera	10/2012			
CHECKED			TITLE: heater, 1000wt, 230v		
COMMENTS:			SIZE	DWG. NO.	REV
<small> PROPRIETARY AND CONFIDENTIAL THE INFORMATION CONTAINED IN THIS DRAWING IS THE SOLE PROPERTY OF MYTEE LLC. ANY REPRODUCTION IN PART OR AS A WHOLE WITHOUT THE WRITTEN PERMISSION OF MYTEE LLC IS PROHIBITED. </small>			C	8070-230	0D
			SCALE: 1:2	DO NOT SCALE DRAWING	SHEET 4 OF 5

REVISIONS			
REV.	DESCRIPTION	DATE	APPROVED
OD	ORIGINAL DRAFT	1/3/2014	JFL
A	G004A REPLACED WITH G004	3/19/2014	ML
B	ADDED H212 AND B170	3/19/2014	ML
C	ADDED H029	6/18/2014	ML
D	ADDED H423, B110	7/11/2014	ML
E	ADDED B241, B111	4/15/2015	ML
F	RPLACED B136 WITH B652	4/13/2016	ML

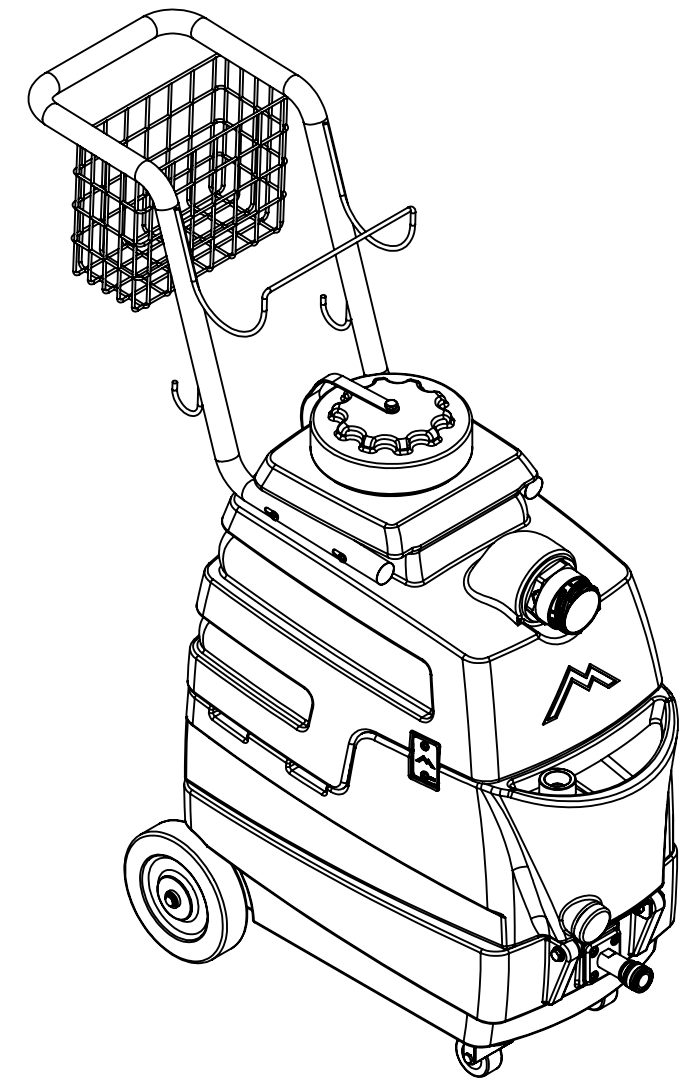

	NAME	DATE	MYTEE <small>858-679-1191</small>	
DRAWN	M.LaBarbera	1/2014		
CHECKED			TITLE:	
COMMENTS:			Mytee Lite	
PROPRIETARY AND CONFIDENTIAL <small>THE INFORMATION CONTAINED IN THIS DRAWING IS THE SOLE PROPERTY OF MYTEE LLC. ANY REPRODUCTION IN PART OR AS A WHOLE WITHOUT THE WRITTEN PERMISSION OF MYTEE LLC IS PROHIBITED.</small>			SIZE DWG. NO. C 8070-230	REV F
			SCALE: 1:24	DO NOT SCALE DRAWING
			SHEET 5 OF 5	